



# TEREX

# TV1300-1 & TV1400-1

## Tandem Asphalt Rollers

<b>OPERATING WEIGHT</b>	7,859 / 9,953 lbs (3,565 / 4,515 kg)
<b>NET ENGINE POWER</b>	40 hp (29.8 kW)
<b>STATIC LINEAR LOAD</b>	76.6 / 90 lbs/in (13.7 / 16.1 kg/cm)
<b>CENTRIFUGAL FORCE</b>	7,175 / 8,090 - 11,685 lbs (32.2 / 36 - 52 kN)



TANDEM ASPHALT ROLLERS

### Operating Data, Standard Equipment

	TV1300-1	TV1400-1
Operating weight	7,859 lbs (3 565 kg)	9,953 lbs (4,515 kg)
Basic weight	7,418 lbs (3,365 kg)	9,512 lbs (4,315 kg)
Static linear load	76.6 lbs/in (13.7 kg/cm)	90 lbs/in (16.1 kg/cm)
Total length	93.5 in (2,375 mm)	93.5 in (2,375 mm)
Total width	54 in (1,370 mm)	58 in (1,470 mm)
Turning radius (inside)	97 in (2,465 mm)	95 in (2,415 mm)
Total height	104 in (2,650 mm)	104 in (2,650 mm)
Frame articulation degrees	30°	30°
Frame oscillation degrees	15°	15°
Frequency (Hz) VPM	3,120 (51 Hz)	2,580 / 3,120 (43 / 52 Hz)
Amplitude	.022 in (0.5 mm)	.020 / .039 in (0.5 / 1 mm)
Centrifugal force	7,175 lbs (32.2 kN)	8,090 / 11,685 lbs (36 / 52 kN)
Gradeability % (with vibration on)	30%	30%
Gradeability % (with vibration off)	40%	40%
Drum thickness	.6 in (15 mm)	1 in (25 mm)

# Tandem Asphalt Rollers

## TV1300-1 & TV1400-1

### Specifications

Engine	
Manufacturer, model	Deutz F3L 1011F
Type	3-cylinder, diesel engine
Power rating at 2,500 rpm	40 hp (29.8 kW)
Cooling system	Air
Electrical System	
Nominal voltage	12 Volt
Battery	770 CCA
Alternator	65 Amp
Hydrostatic Transmission	
Hydrostatic drive. Forward and reverse selected from joystick. Infinitely variable speed control forward and reverse. 0 – 6.2 mph (0 – 9.98 km/h)	
Drive	
Dual radial piston drive motors.	
Brakes	
<b>Service brake:</b> Hydrostatic drive provides dynamic braking.	
<b>Parking brake:</b> Spring applied failsafe.	
Steering	
Heavy-duty articulated steering. Unique steering arm provides excellent visibility and improved leg room.	
Fluid Capacities	
Fuel tank	12 gal (44 L)
Hydraulic system (includes tank)	12 gal (44 L)
Water tank	53 gal (200 L)
Operator's Area	
Open operator's seat with functional design, excellent all-round visibility and user-friendly operator controls.	
Operator's suspension seat with hydraulic cushioning and lap belt; weight, height and longitudinally adjustable.	

### Standard Features

Vandal protection package
Back-up alarm
2 scraper bars per drum
Hydraulic test points
Electrical diagnostics system (LED lights)
Tow valve
12 volt battery disconnect
Pressure and gravity water
ROPS

### Dimensions

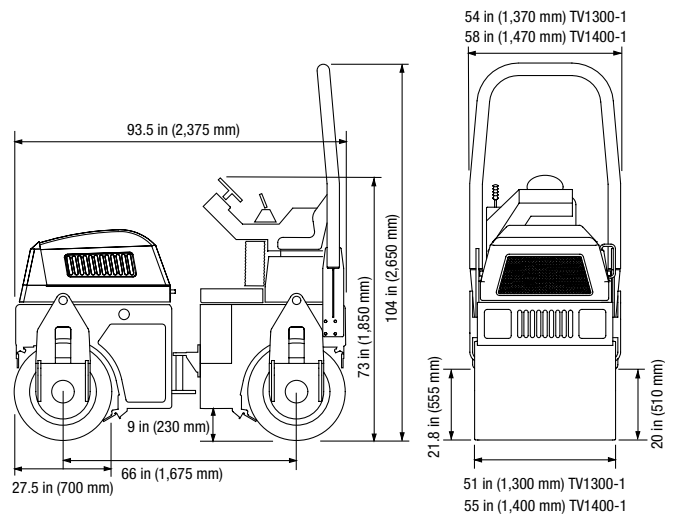

### TEREX Construction Americas

8800 Rostin Road  
Southaven, MS 38671  
USA

TEL 662-393-1800  
SALES 866-837-3923  
PARTS & TECH SUPPORT 888-201-6008  
FAX 662-393-1700  
EMAIL sales@terexca.com  
WEB terexca.com

For more information, product demonstration, or details on purchase, lease and rental plans, please contact your local TEREX Distributor.